

90° Hybrid Coupler, 3 dB, 1–6 GHz, SMA Female

Broadband 90-degree hybrid coupler designed for equal power division with quadrature phase relationship over 1–6 GHz.

FREQUENCY

1–6 GHz

SPLIT

3.01 dB

ISOLATION

≥ 20 dB

VSWR

≤ 1.25 :1

HIGHLIGHTS

- Broadband 1–6 GHz operation
- Equal 3 dB power split
- 90° phase difference between outputs
- Isolation ≥ 20 dB
- 50 Ω system impedance

APPLICATIONS

- Balanced amplifier systems
- I/Q signal generation
- Power combining and splitting
- Laboratory and RF test systems

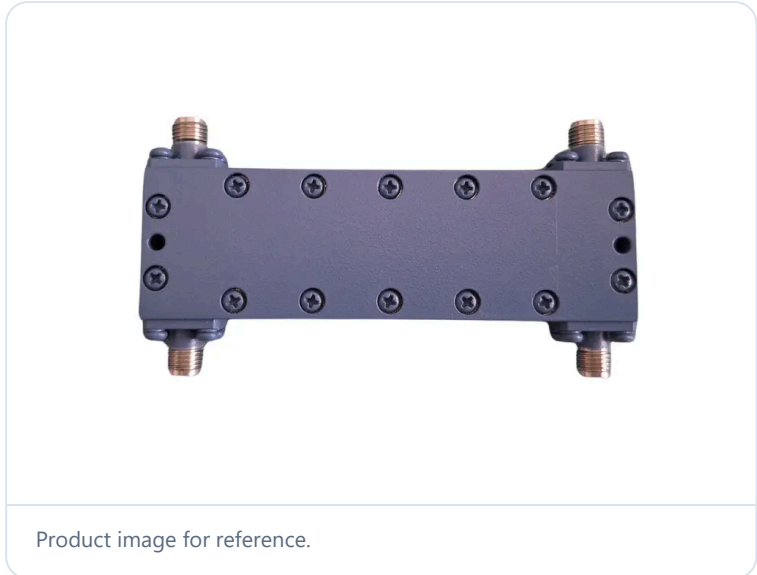

Handle RF connectors with care. Keep mating surfaces clean and protected.

Performance values represent worst-case limits across the specified frequency range. Typical values may be lower under nominal operating conditions.

Electrical Specifications

Reference Specs

Frequency range	1 to 6	GHz	
Impedance	50	Ω	
Insertion loss	≤ 0.70	dB	Excluding 3.01 dB split
Isolation	≥ 20	dB	
Amplitude balance	$\leq \pm 0.5$	dB	
Phase balance	$\leq \pm 5$	deg	
VSWR	≤ 1.25	:1	All ports
Power (average)	≤ 50	W	
Power (peak)	≤ 1000	W	
Connector type	SMA Female	—	

Environmental & Mechanical

Operating limits

Operating temperature	-55 to +85	$^{\circ}\text{C}$	
Humidity	Up to 95	%	Non-condensing
Weight	150	g	

Material & Construction

Mechanical build details

Housing	Aluminum 6061-T6	Chem conversion
Connector body	Stainless steel	Passivated
Center contacts	Beryllium copper	Gold plated

Compliance

Regulatory conformity

RoHS compliance	Yes	—	Lead-free
-----------------	-----	---	-----------

Power handling is valid under matched load conditions. Exceeding rated limits may result in permanent damage.

Mechanical

Outline drawing

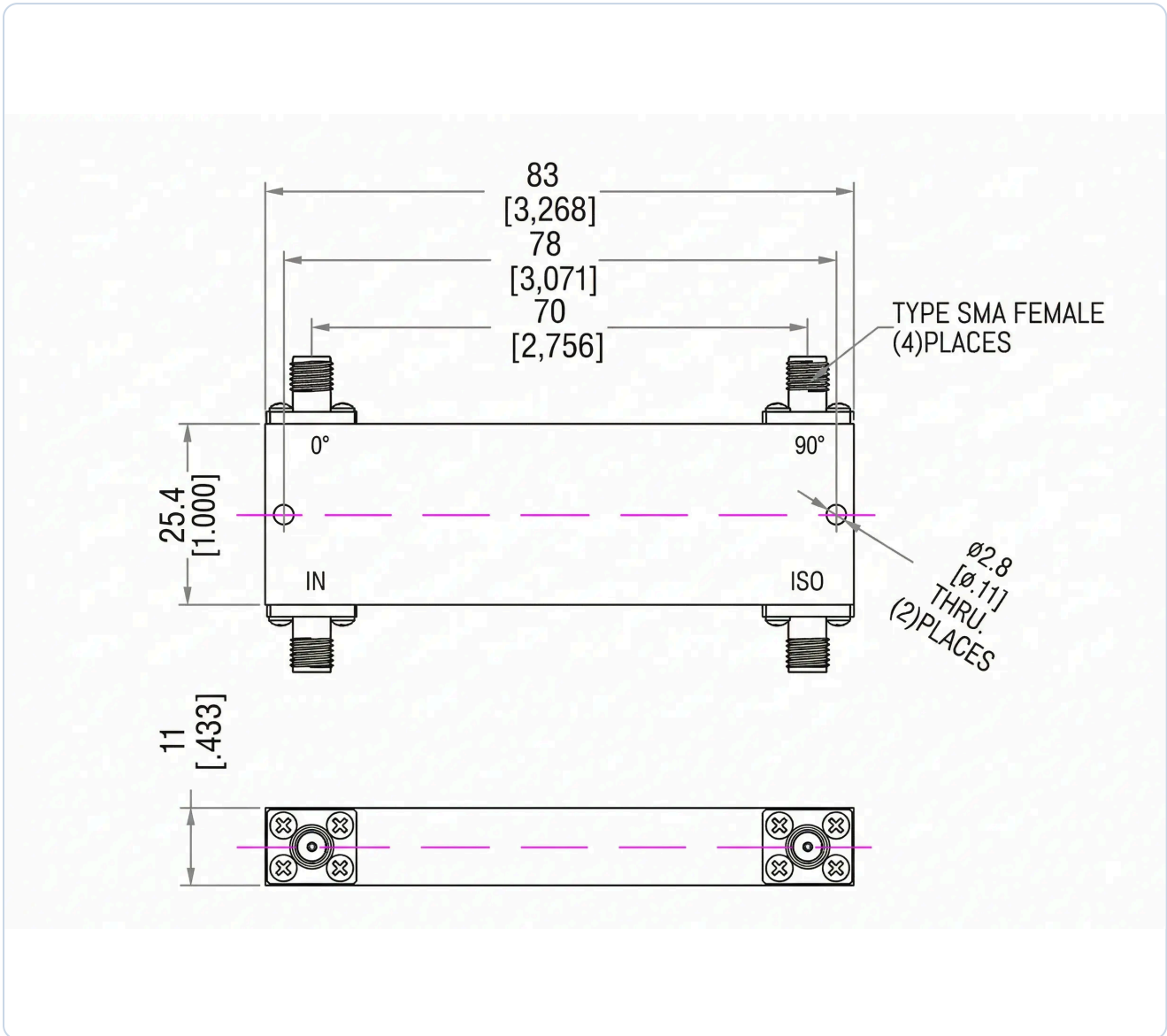

All dimensions are in mm [inch] where applicable.